

REVISION HISTORY			
REV	DESCRIPTION	DATE	APPROVED
5	ECO-01923	4/19/2007	WSS
6	ECO-02099	12/3/07	WSS

			Bill of Material		
ITEM	PART NUMBER	QTY	DESCRIPTION	FILE NAME	REVISION
1	-	1	SIDE PANEL SOLID LIFT-OFF WELDMENT FOR 84H x 32D E CABINET	I000267.iam	6
2	10117-32728	1	Austin Hardware 10117-32728 Black Die cast Lock	10117-32728.iam	-
3	2000614	1	CAM FOR SIDE PANELS	2000614.ipt	-
4	A34062512	2	SOUTHCO SLIDE LATCH, FLUSH	A34062512.ipt	-

**DETAIL A**

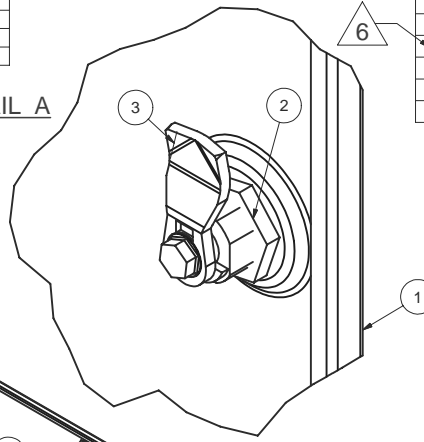

**DETAIL B**

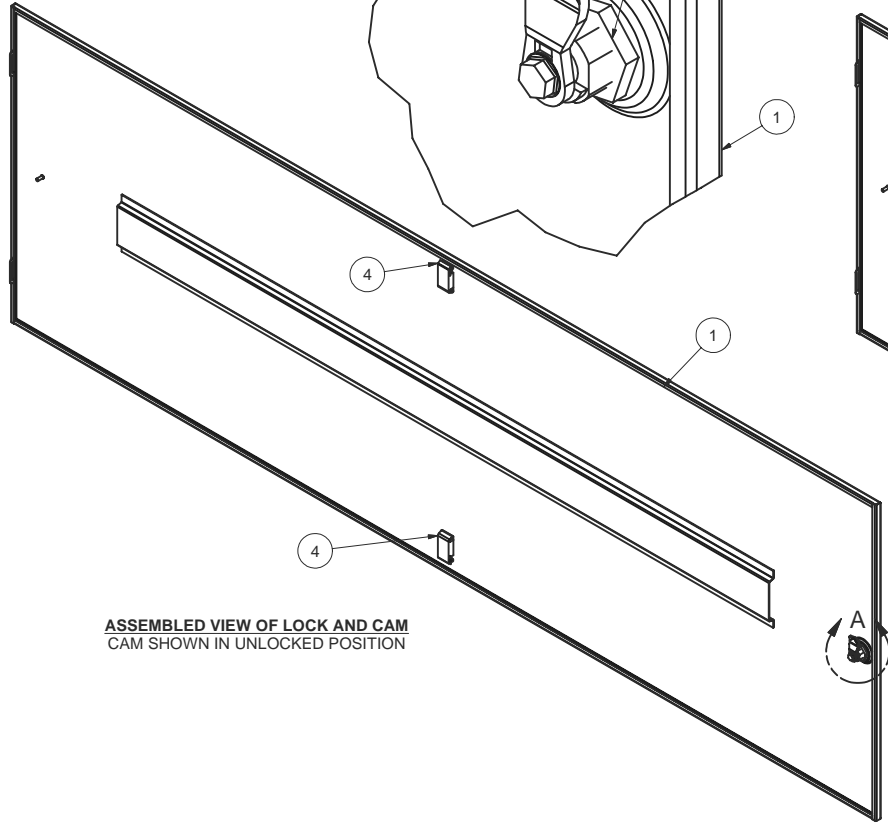
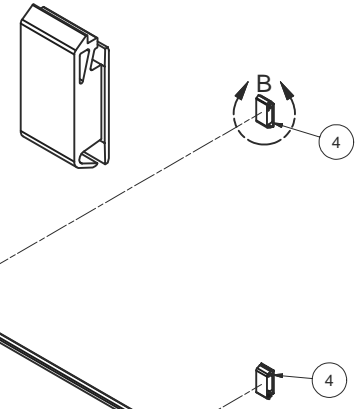

**ASSEMBLED VIEW OF LOCK AND CAM**  
CAM SHOWN IN UNLOCKED POSITION

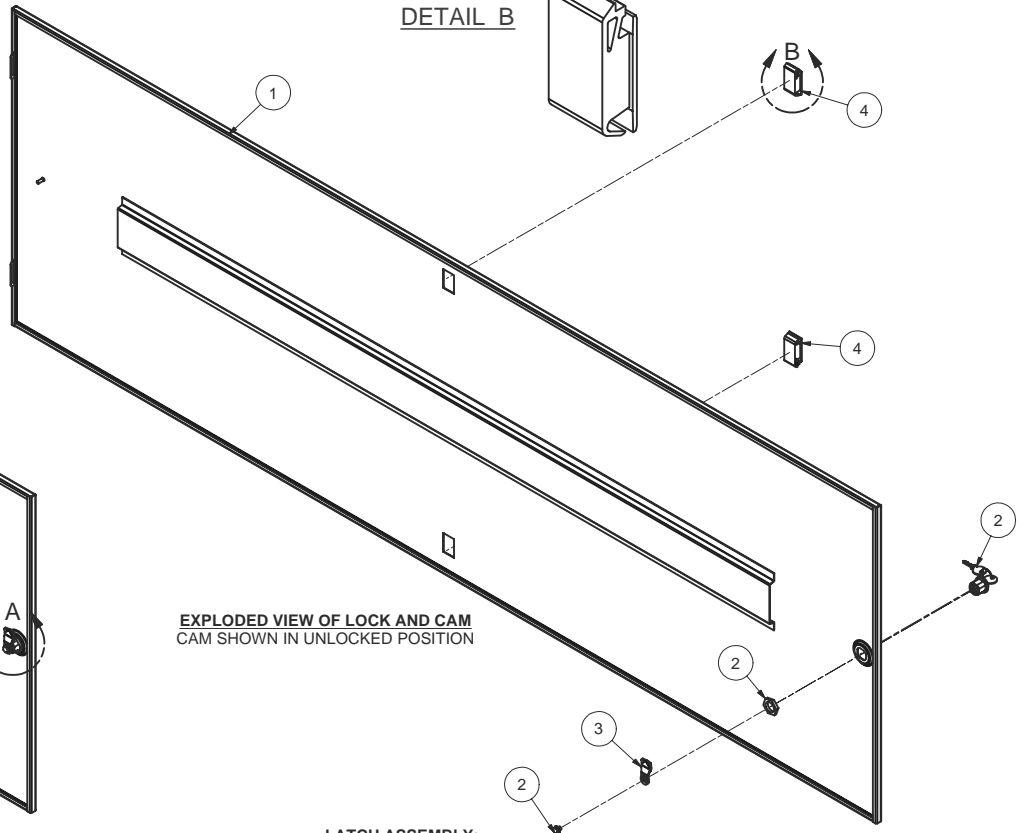

**EXPLODED VIEW OF LOCK AND CAM**  
CAM SHOWN IN UNLOCKED POSITION

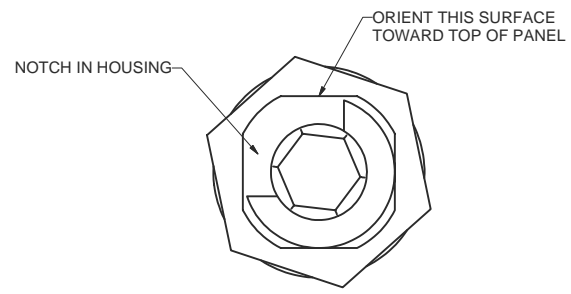

**VIEW 3**  
AS VIEWED FROM INSIDE

**LOCK AND CAM ASSEMBLY:**

1. DO NOT REMOVE KEY FROM LOCK CYLINDER WHEN CYLINDER IS NOT IN THE LOCK HOUSING, LOCK MECHANISM WILL BE DESTROYED.
2. POSITION LOCK HOUSING AS SHOWN IN VIEW 3 - NOTE ORIENTATION OF NOTCH ON ITS INSIDE SURFACE AND THE ORIENTATION OF THE KEY IN CYLINDER.
3. SECURE LOCK HOUSING WITH NUT.
4. POSITION CAM AS SHOWN AND SECURE WITH SCREW.
5. TURN KEY TO VERIFY SMOOTH OPERATION OF LOCK.

**LATCH ASSEMBLY:**

1. SLIP FRONT OF LATCH (OPPOSITE END WITH SPRING) THROUGH HOLE IN SIDE PANEL
2. SNAP BACK END OF LATCH INTO POSITION.
3. LATCH MUST TRAVEL FREELY ONCE INSTALLED - PULL LATCH BACK AGAINST ITS SPRING AND RELEASE. LATCH MUST TRAVEL BACK 1/4" UNDER ITS OWN SPRING TENSION.



THIRD ANGLE PROJECTION  
UNLESS OTHERWISE SPECIFIED ALL DIMENSIONS ARE IN INCHES

INTERPRET DRAWING PER ASME Y14.5M-1994
DIMENSIONAL LIMITS APPLY AFTER APPLICATION OF FINISH
DRAWING NOT TO SCALE
TOLERANCE UNLESS OTHERWISE NOTED:
ANGULAR +/- 1'
.XXXX +/- .010
.XXX +/- .015
.XX +/- .030
.X FOR REF. ONLY

**NOTICE:**  
Use of this document is subject to a confidentiality and nondisclosure agreement with Great Lakes Case & Cabinet Co., Inc. (GLCC) and may not be reproduced, disclosed or utilized in whole or in part without prior written authorization from GLCC.

PART NUMBER:	8410321ELSX100
QTY PER UNIT:	1
MATERIAL TYPE:	-
MATERIAL GAUGE:	-
FINISH:	-
DRAWN	DATE
JAL	4/30/2003
CHECKED & APP.	DATE
CA	5-1-03

TITLE		SIDE PANEL SOLID LIFT-OFF FOR 84H x 32D E CABINET, ASSEMBLY	
GREAT LAKES CASE & CABINET CO., INC.			
P.O. BOX 551 EDINBORO, PA 16412			
PHONE (814) 734-7303 FAX (814) 734-3907			
E-MAIL glcc@greatcabinets.com			
DWG NO:	REV	SHEET: 1 OF 2	
I000266	6		

REVISION HISTORY			
REV	DESCRIPTION	DATE	APPROVED
5	ECO-01923	4/19/2007	WSS
6	ECO-02099	12/3/07	WSS

Bill of Material					
ITEM	PART NUMBER	QTY	DESCRIPTION	FILE NAME	REVISION
1	-	1	SIDE PANEL, SOLID, LIFTOFF, FOR 84H x 32D E CABINET	I000268.ipt	3
2	-	1	STIFFENER FOR 72" H E CABINET LIFT-OFF SIDE PANELS	I000224.ipt	4
3	101208260	1	#10-32 x 1/2"L WELD STUD (NELSON)	101208260.ipt	-

**SPECIAL NOTES:**

1. FINISH PER TD-09-103 (POWDER COAT), CLASS B, TEXTURE LEVEL 3, - ALL SURFACES UNLESS OTHERWISE NOTED.
2. DIMENSIONS APPLY AFTER APPLICATION OF FINISH.
3. INSTALL ITEM 3 ON CENTER PUNCH.

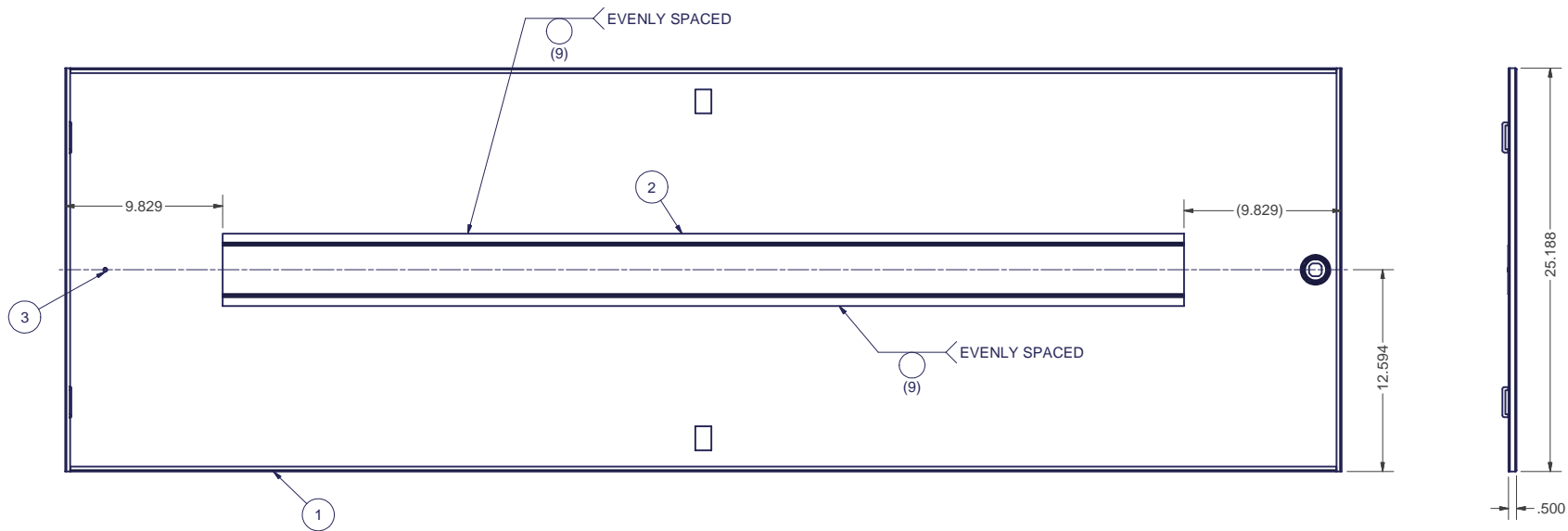
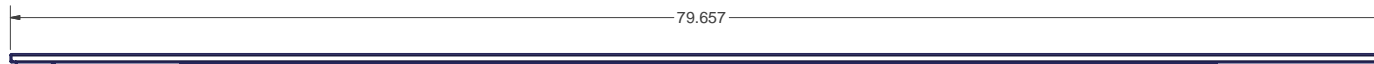
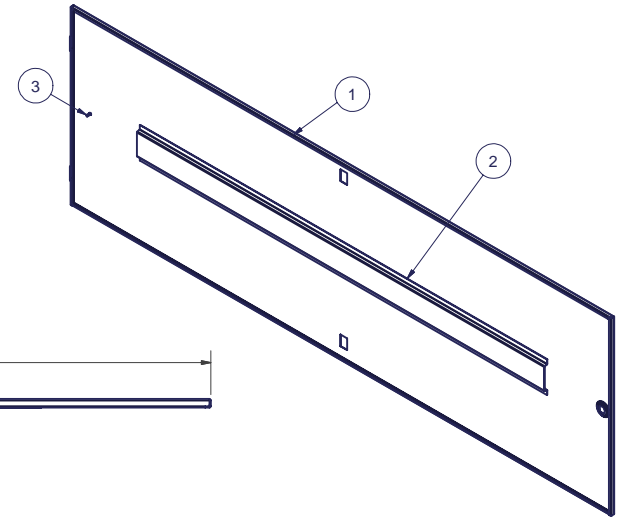

INTERPRET DRAWING PER ASME Y14.5M-1994  
 DIMENSIONAL LIMITS APPLY AFTER APPLICATION OF FINISH  
 DRAWING NOT TO SCALE  
 TOLERANCE UNLESS OTHERWISE NOTED:  
 ANGULAR +/- 1'  
 .XXXX +/- .010  
 .XXX +/- .015  
 .XX +/- .030  
 .X FOR REF. ONLY

**NOTICE:**  
 Use of this document is subject to a confidentiality and nondisclosure agreement with Great Lakes Case & Cabinet Co., Inc. (GLCC) and may not be reproduced, disclosed or utilized in whole or in part without prior written authorization from GLCC.

PART NUMBER: -  
 QTY PER UNIT: 1  
 MATERIAL TYPE: -  
 MATERIAL GAUGE: -  
 FINISH: SEE NOTES  
 DRAWN: JAL DATE: 4/30/2003  
 CHECKED & APP. DATE: 5-1-03  
 CA

TITLE: SIDE PANEL SOLID LIFT-OFF WELDMNT FOR 84H x 32D E CABINET  
 GREAT LAKES CASE & CABINET CO., INC.  
 P.O. BOX 551 EDINBORO, PA 16412  
 PHONE (814) 734-7303 FAX (814) 734-3907  
 E-MAIL glcc@greatcabinets.com  
 DWG NO: I000267  
 REV: 6  
 SHEET: 1 OF 1



UNLESS OTHERWISE SPECIFIED ALL DIMENSIONS ARE IN INCHES

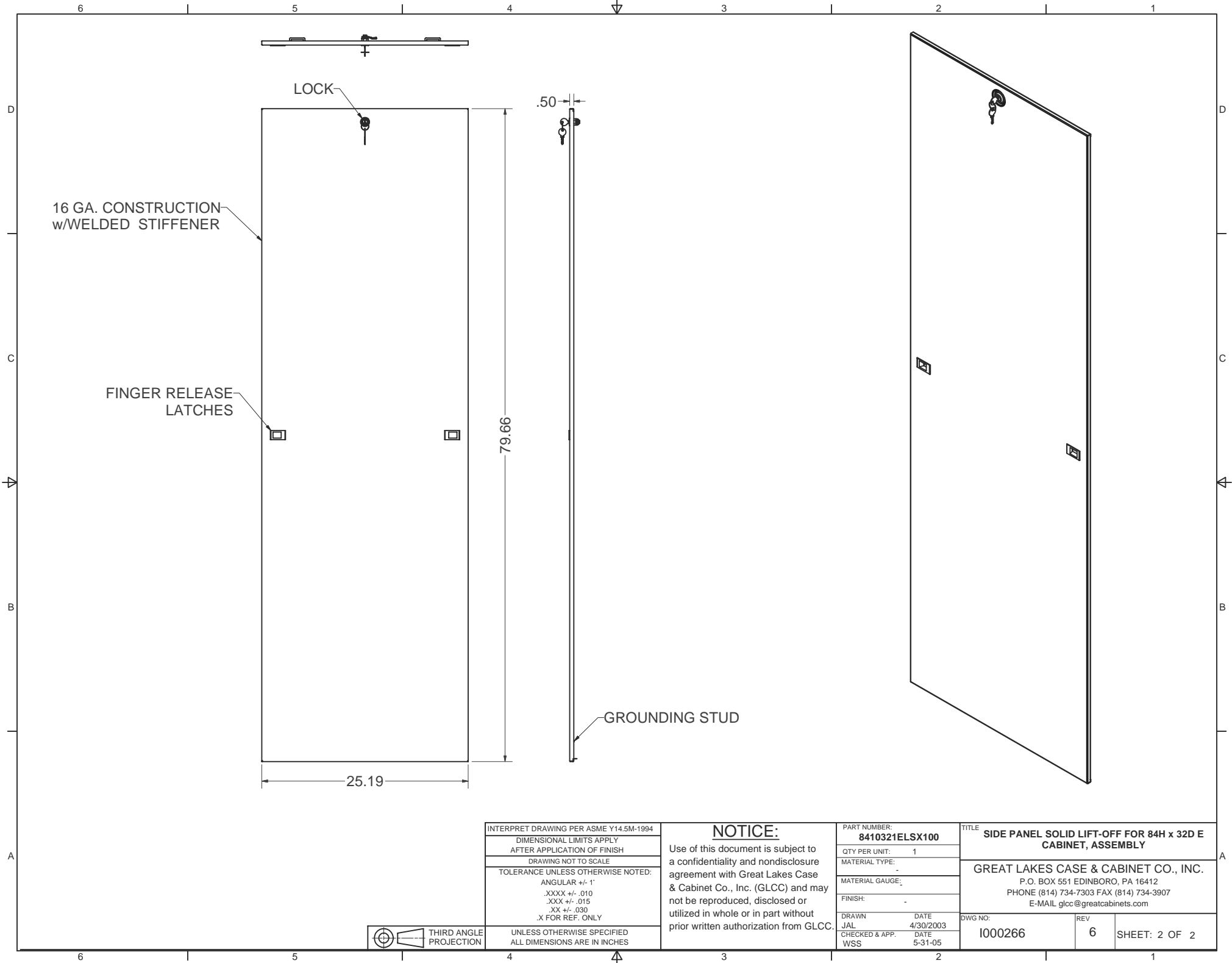

16 GA. CONSTRUCTION  
w/WELDED STIFFENER

FINGER RELEASE  
LATCHES

LOCK

.50

79.66

25.19

GROUNDING STUD



THIRD ANGLE  
PROJECTION

INTERPRET DRAWING PER ASME Y14.5M-1994
DIMENSIONAL LIMITS APPLY AFTER APPLICATION OF FINISH
DRAWING NOT TO SCALE
TOLERANCE UNLESS OTHERWISE NOTED:
ANGULAR +/- 1'
.XXXX +/- .010
.XXX +/- .015
.XX +/- .030
.X FOR REF. ONLY
UNLESS OTHERWISE SPECIFIED ALL DIMENSIONS ARE IN INCHES

**NOTICE:**

Use of this document is subject to a confidentiality and nondisclosure agreement with Great Lakes Case & Cabinet Co., Inc. (GLCC) and may not be reproduced, disclosed or utilized in whole or in part without prior written authorization from GLCC.

PART NUMBER:	8410321ELSX100
QTY PER UNIT:	1
MATERIAL TYPE:	-
MATERIAL GAUGE:	-
FINISH:	-
DRAWN	DATE
JAL	4/30/2003
CHECKED & APP.	DATE
WSS	5-31-05

TITLE		SIDE PANEL SOLID LIFT-OFF FOR 84H x 32D E CABINET, ASSEMBLY	
GREAT LAKES CASE & CABINET CO., INC.			
P.O. BOX 551 EDINBORO, PA 16412			
PHONE (814) 734-7303 FAX (814) 734-3907			
E-MAIL glcc@greatcabinets.com			
DWG NO:	REV	SHEET: 2 OF 2	
1000266	6		